

BioSure
PROFESSIONAL

WATER DISINFECTION SYSTEM
WDS1200X

Model EOS7211-BX

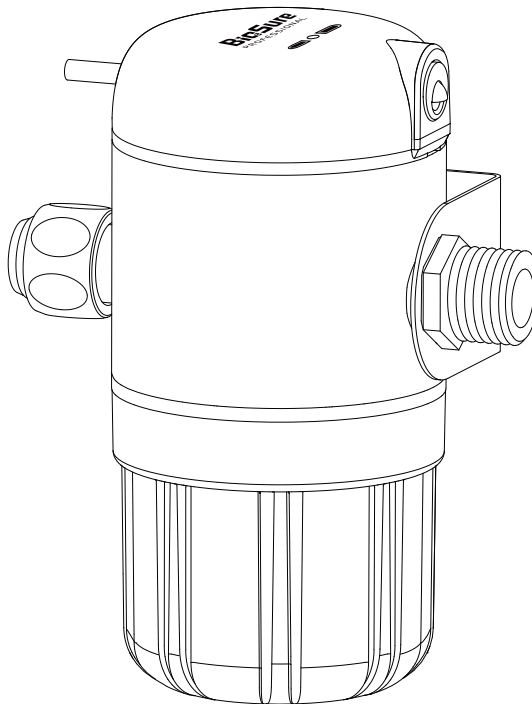

INSTALLATION & OPERATION MANUAL

BIOTEK ENVIRONMENTAL SCIENCE LTD.
www.besgroups.com

PREFACE

This manual contains important information of BioSure Professional Water Disinfection System WDS1200X (Model: EOS7211-BX). Only the correct operation and maintenance of this equipment can make your system perform its best.

Be sure to understand the correct installation, operation and maintenance methods before using this equipment.

This manual contains important safety information, basic installation, operation, and maintenance instructions. Please read this manual carefully to optimize your application. For additional guidance, consult **Biotek Environmental Science Ltd. (BES) Customer Service or your BioSure Professional local authorized dealer.**

DISCLAIMER

The information contained in this document is subject to change without notice. BES shall not be liable for any direct, indirect, incidental, consequential, or other damage alleged in connection with the furnishing or use of this information. BES is not liable for damages on any contact materials due to result of oxidation.

BES makes no warranty of any kind with respect to this information. BES SPECIFICALLY DISCLAIMS THE IMPLIED WARRANTY OF MERCHANTABILITY AND FITNESS FOR A PARTICULAR PURPOSE.

COPYRIGHT

© 2022 Biotek Environmental Science Ltd (Biotek Environmental Science Ltd.) All Rights Reserved.

Reproduction, adaptation, or translation without prior written permission is prohibited, except as allowed under the copyright laws.

VERSION: 2023, April

BioSure Professional is a division of Biotek Environmental Science Ltd. ("BES"). **BES** is a global leading electrolytic technology developer and product manufacturer with pioneering ozone application knowledge and currently holds many exclusive patents for its electrolytic ozone generators and products worldwide.

TABLE OF CONTENTS

PREFACE	1
PACKAGING CONTENTS	3
IMPORTANT SAFETY INFORMATION	4
1. PRODUCT INFORMATION	
1.1 PRODUCT DESCRIPTION	7
1.2 PRODUCT FEATURES	7
1.3 KEY COMPONENTS	8
1.4 SPECIFICATIONS	10
2. INSTALLATION	
2.1 PRECAUTIONS BEFORE INSTALLATION	11
2.2 INSTALLING THE UNIT	12
3. OPERATION	
3.1 CONTROL KEYS & INDICATORS	16
3.2 STARTING YOUR WDS1200X	18
4. MAINTENANCE	
4.1 REPLACEMENT CYCLE OF EOG CELL	20
4.2 CELL CARTRIDGE REPLACEMENT	21
4.3 CELL CARTRIDGE CLEANING PROCEDURE	23
5. TROUBLESHOOTING	24
WARRANTY INFORMATION	27

PACKAGING CONTENTS

In order to ensure that the products can be delivered to consumers completely, BES will confirm the integrity of accessories and packaging through quality control before the products are sold. After you receive the product, please check whether there are any packaging defects, cracks, joint damage, etc., to confirm that there is no damage during transportation.

If you find any damage, please notify your freight forwarder and BES immediately.

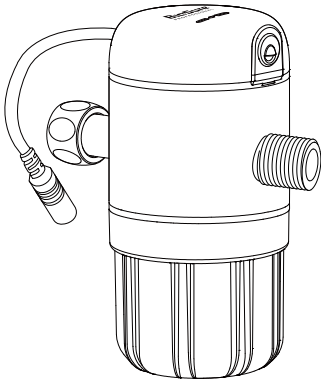

Main Device

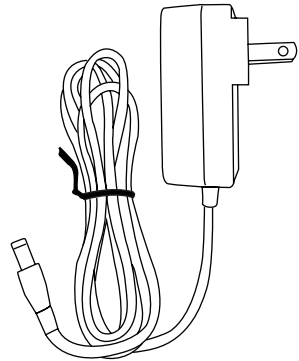

Power Supply

AC100-240V
Wire Length 1.5m

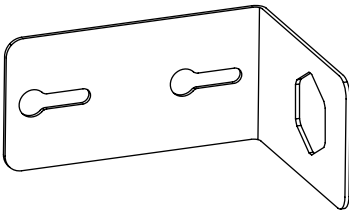

Wall-Mount

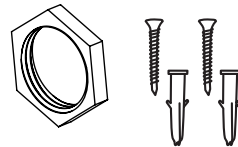

**Hex nuts (x1)
Phillips Screws (x2)
& Plastic Wall Anchors (x2)**

IMPORTANT SAFETY INFORMATION

To avoid personal injury or property damage to the user or others, please follow the following safety instructions :

Explanation of Safety and Notice Symbols

 **WARNING** **WARNING** indicates a hazardous situation which, if not avoided, **COULD** result in death or serious injury.

 **CAUTION** **CAUTION** indicates a hazardous situation which, if not avoided, **COULD** result in injury or property damage.

NOTICE **NOTICE** is used to address practice that is required and must be followed.

----- **READ AND SAVE THESE STRUCTIONS** -----

Electrical Safety and Basic Safeguards

WARNING

- All service work must be performed by a qualified and authorized technician. NEVER attempt to disassemble, repair, or remodel the unit yourself. Doing so will void your warranty and can lead to fire or electric shock. If the product malfunctions or has been damaged in any manner, unplug the unit and contact the BES service department or its authorized local service agent or dealer to arrange service or repair.
- Do **NOT** damage the Power Supply and Power Plug Cord. A damaged Power Supply or Power Plug Cord can cause fire or electric shock.
- Do **NOT** plug or unplug the Power Supply or Power Plug if your hands are wet. Doing so can cause electric shock or injury.
- Do **NOT** use the product if the power connector is loose or damaged.
- Keep the product and power cord away from heated or hot surfaces including space heaters, stoves, and similar electrical appliances. (> 100 cm)

- Stop using the product immediately if you notice any of the following symptoms indicating abnormality or malfunction:
 - The Body of product is abnormally hot or deformed.
 - Smoke coming from the product or there is burning smell.
 - Some part of the product is cracked, loose, or unstable.
 - The product makes strange noises.
 - The display is abnormal.
- If any of the above issues occur, unplug the product immediately and return to authorized agent or dealer for service and repair. Continued use of the product may cause a fire, electric shock, or injury.

NOTICE

- **The power cord of this product is 1.5m. Extension cord should only be used if care is exercised.**
 - Do not place the socket of the extension cord where it is easily splashed by water.
 - The extension cord should not be suspended from the countertop or tabletop, otherwise it may cause tripping.

Specific Safety Information

CAUTION

- Before connecting the unit to power supply, ensure all plumbing connections are secured and leak-free, from shut-off valve to outlet.
- To maintain cosmetic integrity, protect this unit from direct prolonged sunlight exposure.
- Do not immerse the product in water or splash water on it, as this may cause damage to the product. Choose a place to avoid rain or splash water when installing.
- For your safety, **DO NOT** operate the device with any panels or covers removed.

SAFETY INFORMATION OF OZONE

Ozone is categorized as “generally regarded as safe” (GRAS), and is approved by the US Food and Drug Administration (FDA) for food service use as an antimicrobial additive and a disinfectant for food contact surface. The Centers for Disease Control and Prevention (CDC) has also supported that ozone is a safe and effective sanitation method in drinking water, effective against even some of the most resistant pathogens.

This device is designed to instantly transform tap water into ozone water, with the amount of ozone well below typical safety limits and regulations when used correctly. According to the Occupational Safety and Health Administration (OSHA), the concentration standard for continuous exposure to ozone is listed below:

Long term exposure limit	8 Hours	0.10 ppm
Mid term exposure limit	2 Hours	0.20 ppm
Short term exposure limit	15 Minutes	0.30 ppm

The amount of ozone generated by this device is well below typical safety limits and regulations when installed, operated, and maintained correctly. Ozone can be sensed by smell at a level as low as 0.002-0.003ppm. It is normal and expected to be able to detect a mild ozone smell from the water output.

1.1 PRODUCT DESCRIPTION

Water Disinfection System WDS1200X is very simple to use and suitable for installation in home kitchen and bathrooms, or for laundry. The instant ozonated water of WDS1200X can be used for sanitation and deodorization. The system applies a revolutionary advanced electrolytic ozone technology, which features on-demand contribution of reliable sanitizing benefits of dissolved ozone in effective and safe manners.

1.2 PRODUCT FEATURES

- **Instant Start**

- No waiting time. The unit transforms tap water into antibacterial ozone water instantly.

- **Two Working Modes**

- **Faucet Mode:** Preset mode. Suitable for faucets in kitchen and bathroom.
- **Laundry Mode:** Use with the washing machine at home to improve the overall laundry quality.

- **Alarm Warning**

When the efficiency of EOG cell decrease, the recommended replacement cycle of the EOG is due, or the system runs abnormally, the unit will alarms with lights.

- **Scale Preventing**

Our electrolytic ozone generator incorporates a scale-preventing feature that automatically operates polarity reversal to prevent mineral buildup on the electrodes, ensuring optimal ozone generation performance.

1.3 KEY COMPONENTS

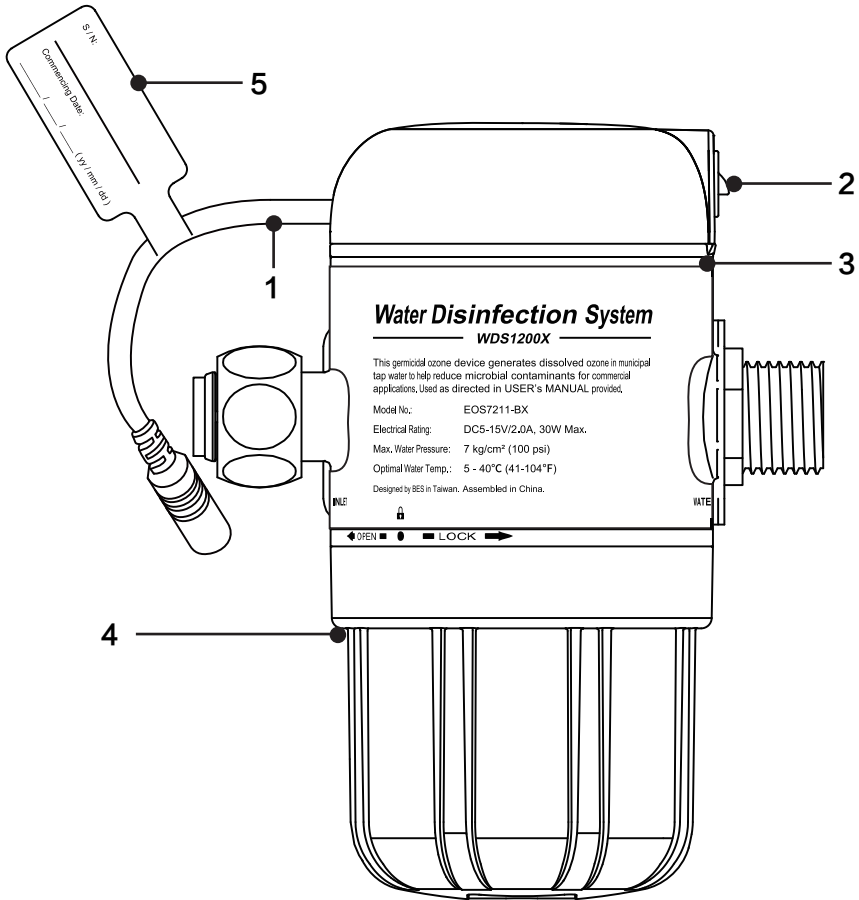

Side View

1. Power Cord and Power Socket

2. Programming Port

3. EOG Status Indicator

4. Electrolytic Ozone Generator (EOG) Cell Cartridge

5. Serial Number

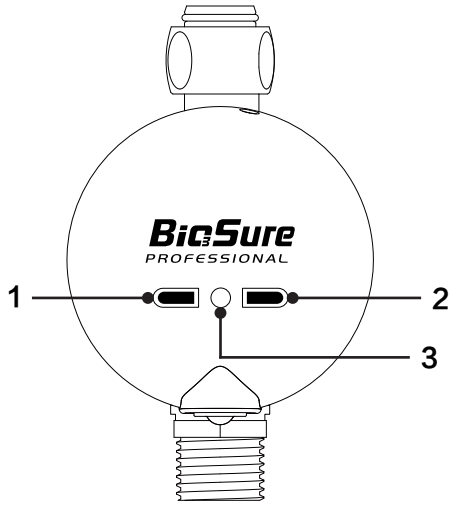

Top View

- 1. Control Button - Mode
 - 2. Control Button - Reset
 - 3. Status Indicator
-

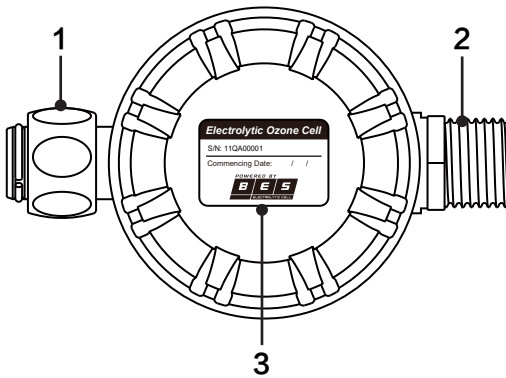

Bottom View

- 1. Water Inlet
 - 2. Water Outlet
 - 3. EOG Serial Number Sticker
-

1.4 SPECIFICATIONS

MODEL		EOS7211-BX
OUTPUT		Ozonated Water
OZONE PRODUCTION		Approx. 120 mg/hr ^{*1}
CONNECTIONS (INPUT/OUTPUT)		1/2" Movable Nut (Female) / 1/2" External Thread (Male)
DIMENSIONS		Φ73 x W118 x H148 mm
WEIGHT (NET)		473 g
IP CLASS		IP54
WATER SUPPLY	Quality	Clean or Filtered Water ^{*2}
	Flow	Up 1450LPH at 3 kg/cm ² with 1/2" tube ^{*3}
	Pressure	≦ 7.0 kg/cm ² (100 psi)
	Optimal Temp.	5 - 40°C
POWER	Adaptor Input	AC 100-240V, 50/60Hz
	Adaptor Output	DC5-15V / 2.0A (Constant Current)
	Rate	30W
AMBIENT TEMP.		5 - 40°C
AMBIENT RELATIVE HUMIDITY		0 - 90% R.H. non-condensing

*1. Environment: 1 atm, 25°C; Water : filtered to 1µm, 20°C, TDS = 60 ppm. Actual performance concentrations may vary from the listed data due to operating conditions (water flow, pressure, temperature, and water quality).

*2. Recommended water quality: filtered ≦ 1µm, TDS >60 ppm, Hardness < 250 ppm (as CaCO₃). Minimum TDS ≧ 30 is required for basic performance.

*3. Minimum ≧ 30LPH is required for activating the function.

2.1. PRECAUTIONS BEFORE INSTALLATION

This device is designed and engineered for easy integration into existing water systems. Please check the device for damage or shortage before installation and be sure you have the tools.

If any parts are damaged, contact your supplier IMMEDIATELY. Do **NOT** install damaged parts.

Tools Needed for Installation:

- Pipe wrench
- Adjustable wrench
- Plumber's Tape
- Adjustable joints (As needed)
- Pipe Clamp (As needed)
- Electric Drill

Installation Precautions

1. For best results, clean and sanitize the water line before installing the unit.
2. Select a location for the unit so:
 - Mount the system after all water filtration processes.
 - It will be in an upright position (You can use the wall mount attached to fix the unit)

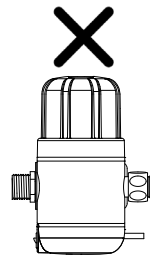
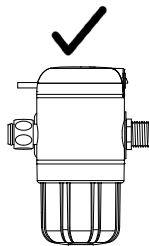

- Indicator lights and cartridge are visible and accessible.
 - Allow sufficient access for cartridge replacement.
 - Other equipment or objects should not lean on or press against the device.
 - Be sure there is a power socket within 1.5m around the installation position.
3. It is highly recommended that a water shut-off valve be installed before and near the unit.
 4. Ensure that adequate hammer arrestors is provided to comply with regional standards and regulations.
 5. If it is used with a washing machine, please disconnect the power supply of the washing machine before installation. A bypass pipeline is recommended to keep the normal operation of the washing machine during future maintenance.

2.2. INSTALLING THE UNIT

• IMPORTANT INFORMATION

The diameter of water inlet and outlet is 1/2" (female inlet /male outlet). Installation position of the equipment must be placed after the water filters. A shut-off valve in front of the water inlet is recommended to facilitate future maintenance or replacement of the EOG cell cartridge.

In case an adjustable joint is used, it's suggest to use plumber's tape and a hose clamp to avoid water leakage. It's recommended to reserve the length of the water pipe for moving or removing the device in the future - the inlet and outlet connectors are designed as one male and one female, which can be directly connected after the equipment is removed.

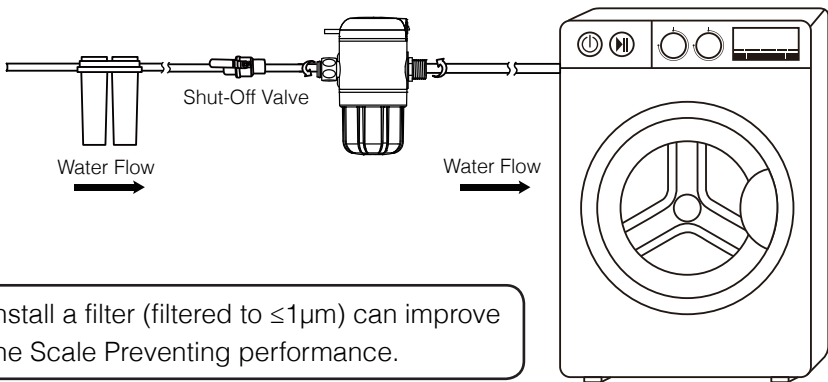
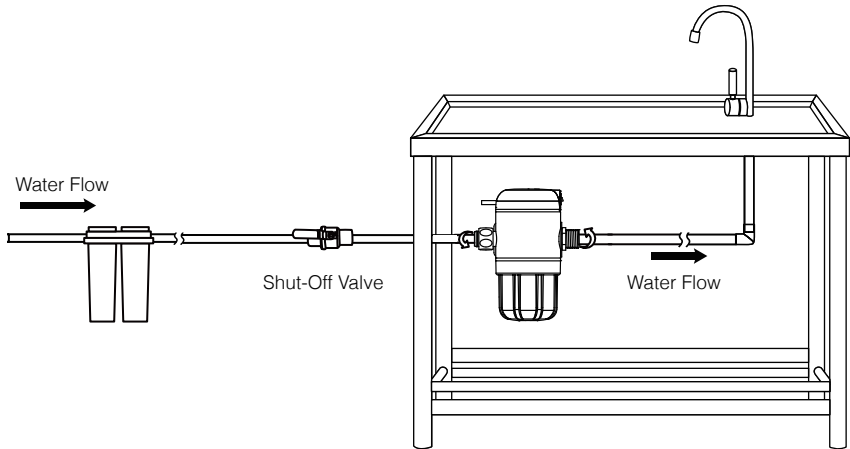

Install a filter (filtered to $\leq 1\mu\text{m}$) can improve the Scale Preventing performance.

Typical Scheme of Installation

• MOUNTING THE UNIT

You can fix the device on the wall by a wall-mount (Attachment). Please follow the previous section "Precautions before installation" to select an appropriate location, and follow descriptions below to secure the device.

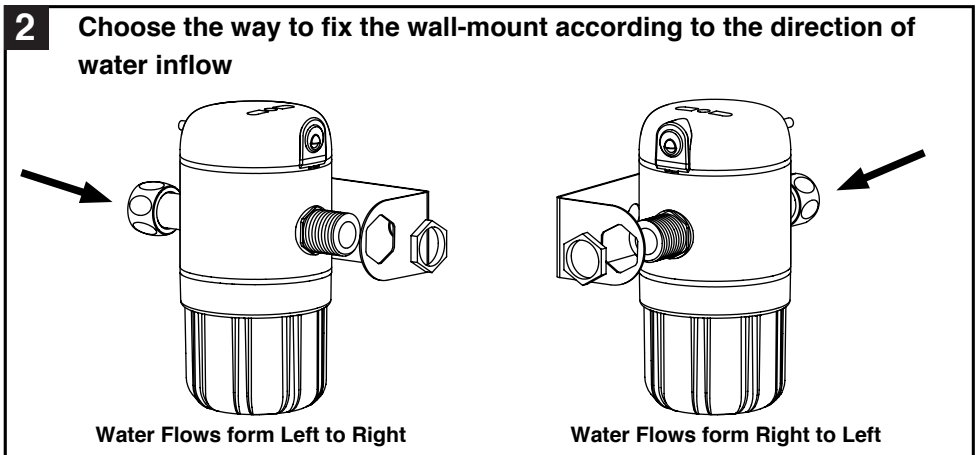
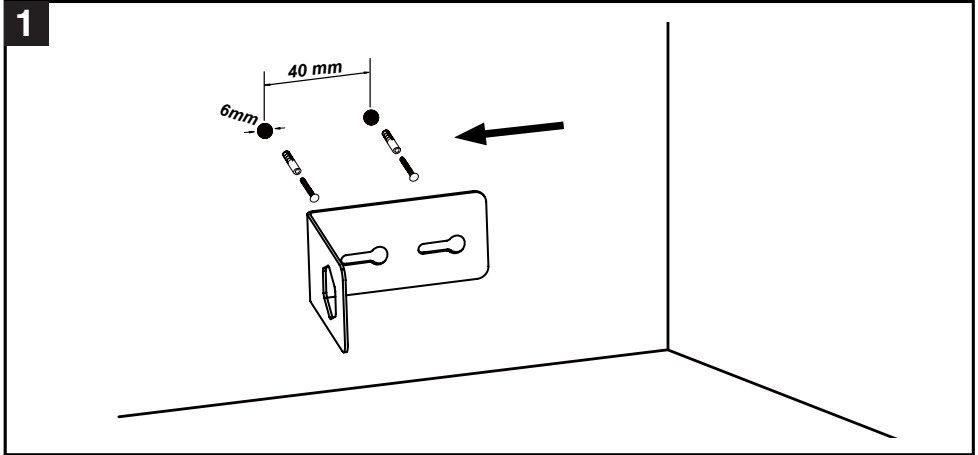

3

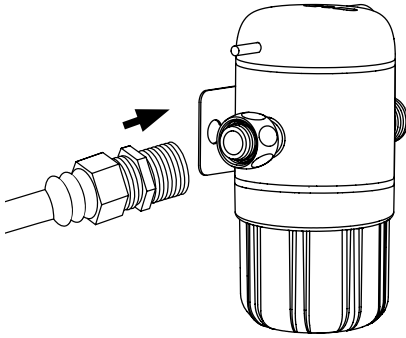

Connect input water tube

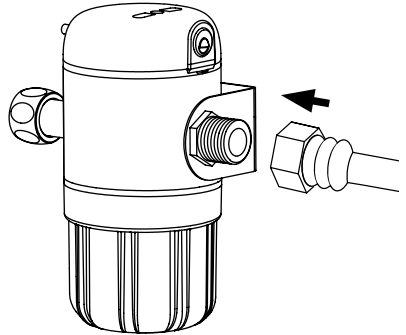

Connect output water tube

4

**Turn on the water supply.
Test for leaks at each connect point.**

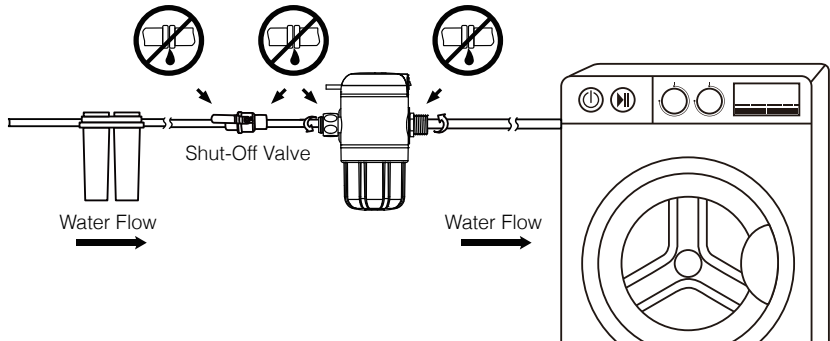
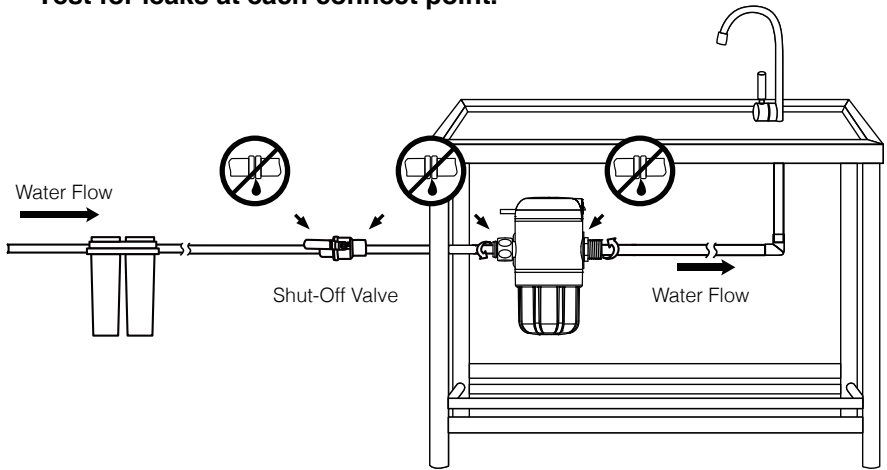

• STARTING YOUR WDS1200X

Connect the power adaptor plug with the power socket of the device. Ensure all plumbing connections are secured and leak-free. Plug the power adaptor into the wall electricity outlet to switch on the device.

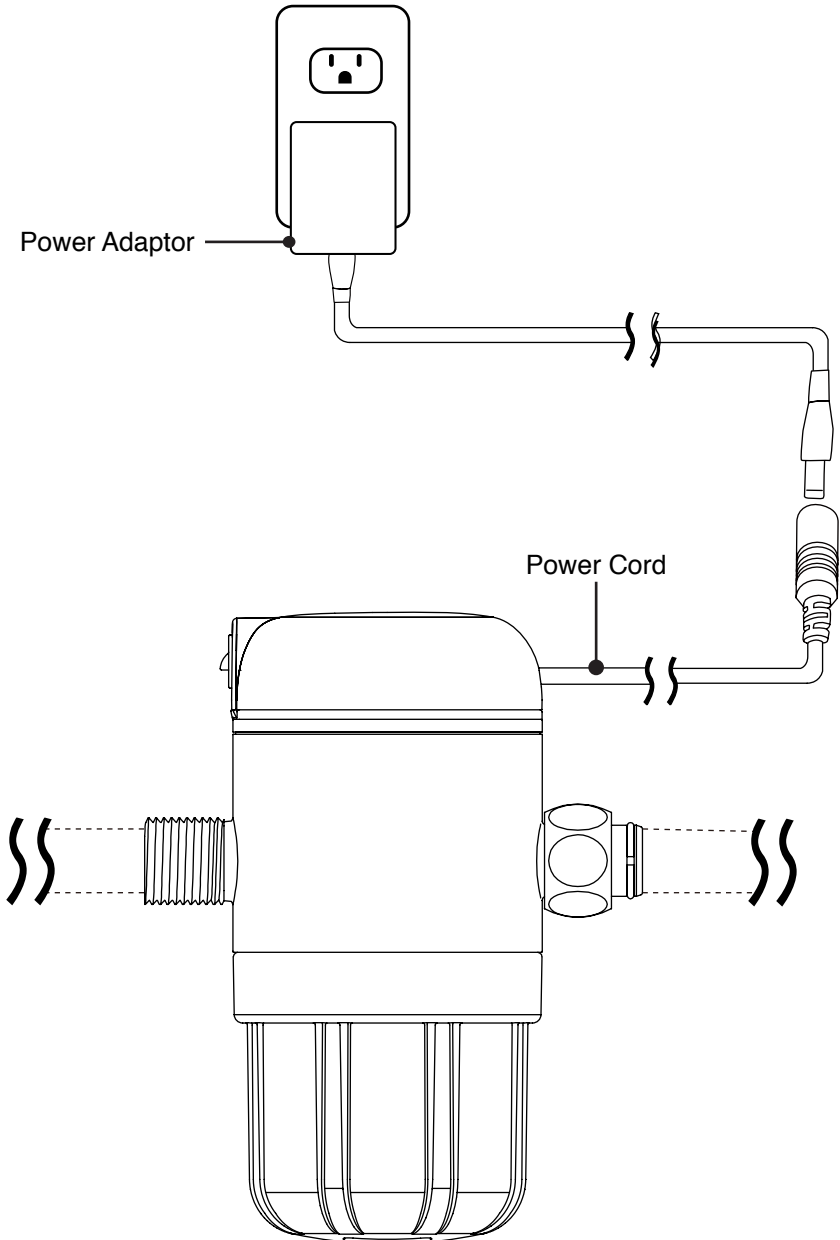

3.1 CONTROL KEYS & INDICATORS



· Status Indicator

(Blue LED)

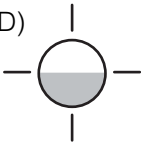

Slow Blinking

- Faucet Mode

(Blue LED)



Steady Solid ON

- Laundry Mode

For abnormal status indications, please refer to troubleshooting in Section 5 (page 24).

· **EOG Status Indicator**

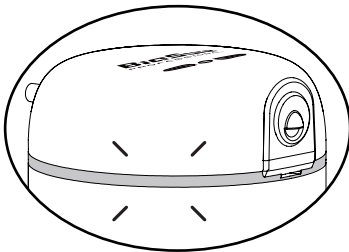
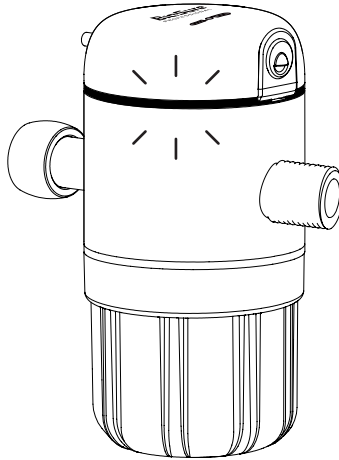

Slow Blue Blinking

System self-checking in the initial 30 sec of start-up.

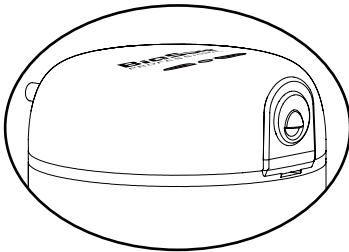

Dark

- Stand-By in normal condition

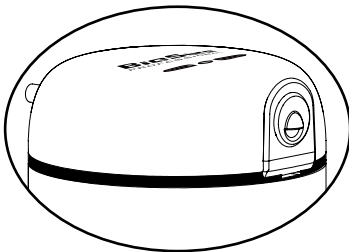

Steady Blue ON

Product function is successfully triggered by an effective water flow.

For abnormal status indications, please refer to troubleshooting in Section 5 (page 24).

3.2 START YOUR WDS1200X

There is no ON/OFF control switch with the unit. The unit is switched ON by connecting the power supply cord into a wall electrical outlet (power supply). All water pipeline connections should be completed before the device powered on. After the unit is powered on, the buzzer will beep once, a 30-second system self-check will be performed. During this period, the control buttons cannot be operated. After 30 seconds, the system enters standby mode, user can operate control buttons at this time.

IMPORTANT!

- After each powered on, the device will perform a self-check for about 30 seconds and the EOG status indicator will blink slowly in blue. Control keys cannot be operated at this time.

· SELECT MODE

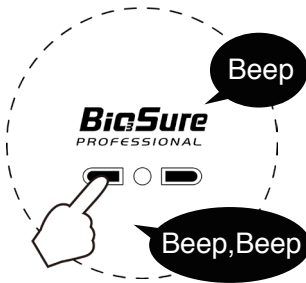

Default setting is "**Faucet**" mode. You can press and hold the "MODE" key for **3** seconds to switch to the "**Laundry**" mode.

When you hear the buzzer beeps **twice**, the mode is switched successfully.

Faucet Mode: Status Indicator slowly blinking

Laundry Mode: Status Indicator steady ON

* Each time the power is restarted, the system maintains the previous mode settings.

* Control keys won't function when the EOG cell is working.

! NOTICE

In **Laundry** mode, when the input flow is greater than the activating flow described in Sec. 1.4., the unit will be triggered to start and generate ozone continuously until 5 minutes after the flow drops under the activating flow.

• PERFORMANCE OF EOG GENERATING THE OZONE WATER

When the EOG starts working, EOG status indicator turns steady ON in blue.

- * However, if the EOG recommended replacement cycle is due (the EOG status indicator flashes slowly in yellow when the unit in standby), the EOG indicator will be steady yellow when the EOG cell is working.

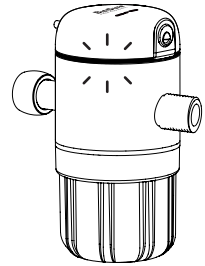

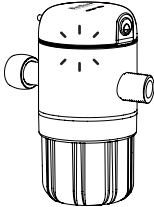
MODE		STATUS OF THE EOG CELL	
Faucet	Blue Blinking Slowly	Standby	No light
		Ozonated Water Generating (function operation)	Blue Steady ON
		Indicating EOG life cycle is due during standby	Yellow Blinking Slowly
		Indicating EOG life cycle is due during function operation	Yellow Steady ON
Laundry	Blue Steady ON	Standby	No light
		Ozonated Water Generating (function operation)	Blue Steady ON
		Indicating EOG life cycle is due during standby	Yellow Blinking Slowly
		Indicating EOG life cycle is due during function operation	Yellow Steady ON

4.1 RECOMMENDED REPLACEMENT CYCLE OF EOG CELL

To get the best performance, it is recommended to replace the EOG cell after 1000 working hours of usage*. The unit equipped a built-in timer that will remind you when the usage hours expired: the EOG status indicator blinks slowly in Yellow and the EOG status indicator will light steady Yellow when the EOG cell is producing ozone water. When noticing the prompt, please replace the EOG cell as soon as possible**. In addition, be careful that hard water or high mineral content water ($\text{CaCO}_3 > 250 \text{ ppm}$) will accumulate scale faster and could affect the EOG performance.

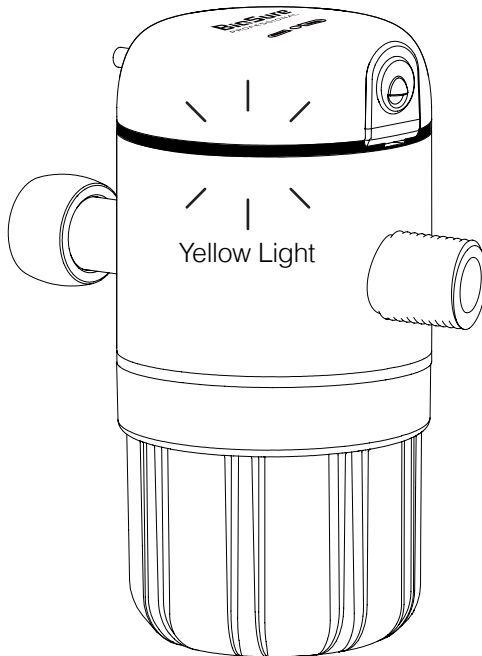

* 1000 working hours are the actual EOG working hours for ozone water production, which is about 2-3 years in general use.

** The unit can still operate after the warning is issued, but the efficiency of making ozone water will keep on reducing in a certain extent and no alarm for EOG abnormal.

4.2 EOG CELL CARTRIDGE REPLACEMENT

The EOG cell cartridge can only be obtained from BioSure Professional or BES authorized distributors. Please confirm the product model and serial number before ordering.

1. Disconnect power supply.
2. Close the water shut-off valve or disconnect input water.
3. Hold body of device steady, and twist the EOG cell cartridge clockwise till the dot on the metal ring lines up the unlock icon  on the device. Pull the cartridge carefully to remove for replacement, and dispose of appropriately.

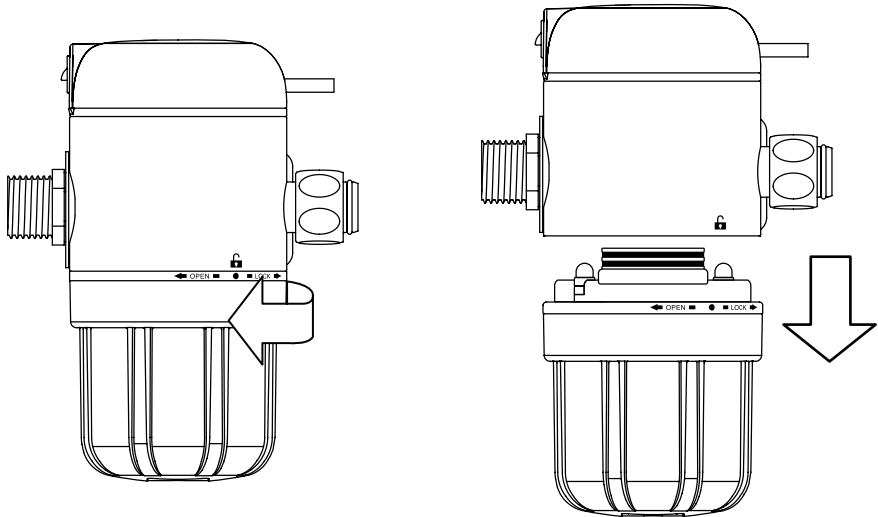

4. Reverse the new EOG cell cartridge, write down the date on the serial number sticker in permanent marker. Reverse the procedures described above and make sure the dot on the metal ring lined up the lock icon  on the device.

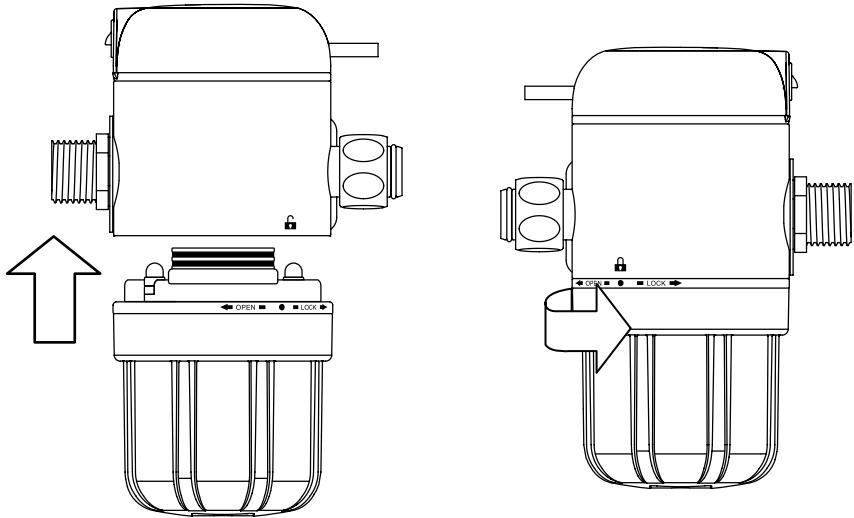

5. **Reset the timer:** Follow the method below to reset the timer so that you can get the replacement alarm at correct time in the future. **During stand-by period, press and hold both "MODE" and "RESET" key for 8 seconds***. The timer is reset successfully when you hear 3 beeps, and the slowly blinking Yellow light gone simultaneously. Reset the timer won't affect your previous settings.

* The status indicator will start to display blue/white light blinking alternately.

4.3 EOG CELL CARTRIDGE CLEANING PROCEDURE

Decreased EOG cell generation efficiency may be caused by scale build up on its electrodes. Please follow the steps below to clean it:

1. Power off the Unit

2. Fill the EOG Cell Cartridge with Scale Cleaner

Close the shut-off valve in front of the unit, detach the EOG cartridge as described in section 4.2. Fill the cartridge with scale cleaner.

* The scale cleaner can be made of 20-50% vinegar or 50% citric acid solution. It is better to use hot water for preparation, and be careful not to scald yourself during the mixing process.

* After preparation, let it sit for a period of time according to the instructions of the scale cleaner (if the cleaning solution temperature is above 50°C, soak for at least half to 1 hour. If at room temperature, extend the soaking time).

3. Wait for Reaction

Wait for a while according to the instruction of the scale cleaner (at least 30min).



4. Pour out the Solution in the Cartridge and Rinse it with Clean Tap Water

Rinse the cartridge with clean tap water at least 3 times.

5. Follow the instructions in section 4.2 to reinstall the EOG cell cartridge and switch-on the shut-off valve to complete the cleaning procedures.

Reference the following guide to self-check your problems before requesting repairs. If you come into a conclusion that problem has occurred, do NOT attempt to disassemble and repair the product yourself, but contact BES Group or your dealer for support. Please have the model number and serial number of the device available when calling for support.

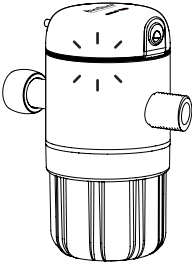
CHART OF LIGHT FOR SYSTEM ABNORMAL

		CAUSE / STATUS
Yellow Blinking Slowing during standby	Blue blinking during faucet setting; Blue steady during laundry setting	Recommended replacement cycle of the EOG cell cartridge is due.
Yellow Steady ON during operation		
Blue Blinking Slowing during operation	Blue / White light blinking alternately	Low water TDS, low electrolytic efficiency. Refer to problem 2 in the below table.
Yellow Steady ON during operation		EOG overcurrent by short-circuited or high water TDS. Refer to problem 3 in the below table.

Sometimes suspected problem is remedied by disconnecting the power plug and then re-connecting it.

Problem 1	No sign of power. Light effects are absent.
Possible Cause	<ol style="list-style-type: none"> 1. Power Supply is inoperable 2. Master control board (PCB) out of order
Corrective Action	<p>Check if the power socket on the wall functions normally. Check if the power connection between power adaptor and the unit correctly.</p> <p>If the symptom remains, contact your maintenance person or authorized service agency.</p>

Problem 2	EOG status indicator shows blue light slowly blinking and the status indicator shows blue/white light blinking alternately.
Possible Cause	<p>The EOG cell efficiency decreased. The reason could be:</p> <ol style="list-style-type: none"> 1. Input water quality doesn't fit the requirement (TDS too low) 2. Scale accumulated on the electrodes of the EOG cell.
Corrective Action	<p>Check the water quality. If the TDS is lower than the requirement, adjust the input water TDS.</p> <p>If the issue happens after the device has been worked for a period of time, scale accumulate could be the reason. Please clean the EOG cell according to Sec. 4.3. If the symptom remains, contact your maintenance person or authorized service agency.</p>

Problem 3	EOG status indicator shows Yellow light steady ON and the status indicator shows blue / white light blinking alternately. All function suspended.
Possible Cause	An overcurrent occurs in the EOG cell, it could be some conductivity foreign materials stuck between the electordes of the EOG.
Corrective Action	Flush it's inner space with clean tap water to remove the foreign materials. If the symptom remains, contact your maintenance person or authorized service agency.

Problem 4	The EOG status indicator blinks slowly in Yellow during stand-by period. When the EOG cell is producing ozone water, the EOG status indicator lights steady Yellow.
Possible Cause	Recommended replacement cycle of the EOG cell cartridge is due.
Corrective Action	Replace a new EOG cell cartridge (Refer to. Sec. 4.2) * Contact your BioSure Professional dealer for the EOG cell cartridge.

Problem 5	There is no water output, but the EOG cell is activated to produce ozone water and shut down within seconds .
Possible Cause	There exists water hammer effect within the water line.
Corrective Action	Install a water hammer arrester or reduce the water pressure.

WARRANTY INFORMATION

LIMITED WARRANTY

Equipment manufactured by Biotek Environmental Science Ltd. has been constructed of the finest materials available and manufactured to high quality standards. When installed in accordance with manufacturer's recommendations, and under normal use and service, new BioSure Professional WDS1200X units are warranted to be free of defects due to poor materials or workmanship for the period of time listed below (following the date of purchase):

- Main Body: 2 years (Consumables not included)
- EOG Cell Cartridge: 6 months or the day that recommended replacement cycle is due (whichever comes first)

EXCLUSIONS

This warranty may be voided in the case of:

1. Defects caused by improper system installation, storage or handling prior to placing of the equipment into service.
2. Attempted to repairs or installation by unauthorized service agencies or personnel .
3. Expense of normal maintenance, calibration, or regular adjustments as specified in operating and maintenance instructions of this manual, and/or labor involved in moving adjacent objects to gain access to the equipment.
4. Damages due to alterations, abuse, fire, flood, or acts of nature.
5. Failure to follow BES Group instructions for use, care, or maintenance.
6. Removal, alteration, or defacing of BES Group-affixed serial number and other labels.
7. Man-made structural damage.
8. Use of fluids other than clean, potable water.

This warranty is conditional upon Biotek Environmental Science Ltd. receiving notice of any defect subject to this warranty within thirty (30) days of its original discovery by the User/Buyer.

Biotek Environmental Science Ltd. reserves the right to make changes in design or add any improvements on any product. The right is always reserved to modify equipment due to factors beyond our control and continuous product development.

If shipment is damaged in transit, the purchaser should make a claim directly upon the carrier. Careful inspection should be made of the shipment as soon as it arrives and visible damage should be noted upon the carrier's documentation. Damage should be reported to the carrier. This damage is not covered under this warranty. Prices and specifications are subject to change without notice.



CONTACT INFORMATION

BES Group / Biotek Environmental Science Ltd.

info@besgroups.com

www.besgroups.com